

1. External Dimensions (Unit:m/m)

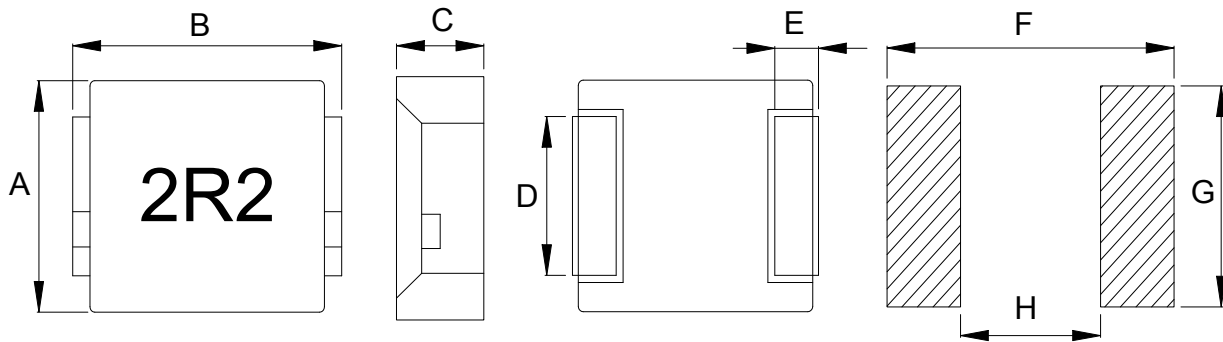

Type	A	B	C	D Typ.	E Typ.	F Typ.	G Typ.	H Typ.	Q'TY/Reel
APS07A50	6.6±0.3	7.7Max	5.0Max	3.0	1.7	8.4	3.5	3.6	1000

2. Part Number Code

APS	07	A	50	M	2R2
Series Name	Dimensions: L*W	Materials	Dimensions: H	Tolerance ±20%	Inductance

3. Electrical Characteristics

Part Number	Inductance (uH)	Test Conditions	DC Resistance (mΩ) Max.	DC Current Irms(A) Typ.	DC Current Isat(A) Typ.
APS07A50M2R2	2.2	100K Hz/1V	12.3	10.1	14.14

Notes:

- 1) All test data is referenced to 25°C ambient.
- 2) Absolute maximum voltage 30V DC.
- 3) Operating temperature range -40°C to +125°C (Including self - temperature rise).
- 4) Irms :DC current(A) that will cause an approximate ΔT of 40°C.
- 5) Isat :DC current(A) that will cause I_o to drop approximately 40%.
- 6) The part temperature (ambient + temp rise) should not exceed 125°C under worst case operating conditions. Circuit design and other cooling provisions all affect the part temperature, part temperature should be verified in the end application.

4. Test Data

ELECTRICAL CHARACTERISTIC				MECHANICAL DIMENSIONS			
SPEC	$L_0(\mu\text{H})$	$L_{\text{Isat}}(\mu\text{H})$	DCR(m Ω)	A(mm)	B(mm)	C(mm)	D(mm)
TOL	2.2	$(L_0 - L_{\text{Isat}}) / L_0 \approx 40\%$	12.3	6.6 \pm 0.3	7.7Max	5.0Max	3.0Ref
No.	$\pm 20\%$		Max				
1	2.24	1.50	8.74	6.64	7.22	4.95	OK
2	2.07	1.39	8.64	6.66	7.16	4.93	OK
3	2.17	1.44	8.66	6.64	7.21	4.95	OK
4	2.18	1.47	8.68	6.64	7.20	4.93	OK
5	2.16	1.45	8.71	6.64	7.19	4.90	OK
6	2.18	1.47	8.71	6.65	7.20	4.90	OK
7	2.06	1.37	8.65	6.65	7.19	4.93	OK
8	2.05	1.36	8.74	6.64	7.16	4.93	OK
9	2.08	1.38	8.67	6.66	7.20	4.95	OK
10	2.06	1.39	8.74	6.65	7.23	4.90	OK

Test Equipments: IM3536,VR126,VR7210,Calipers

Curve:

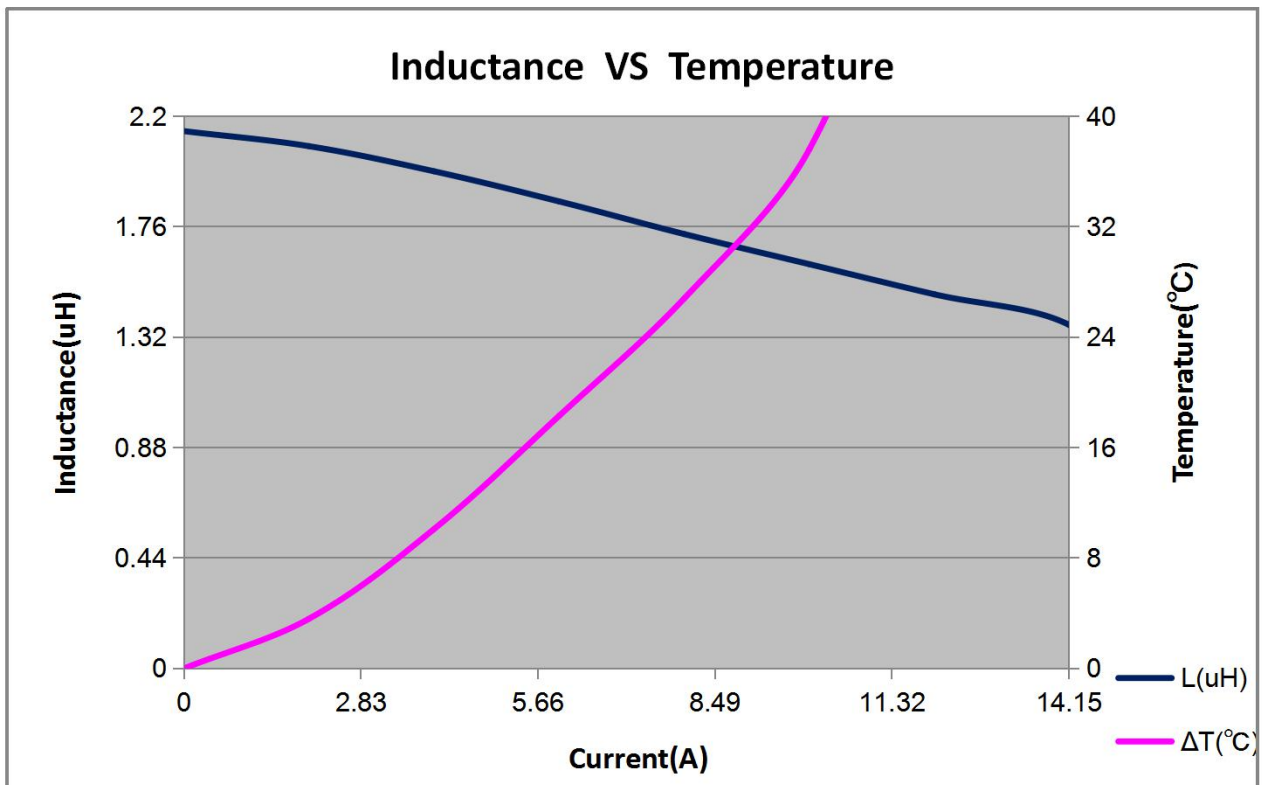

5. Test and Measurement Procedures

5.1 Test Conditions

- 5.1.1 Unless otherwise specified, the standard atmospheric conditions for measurement/test as:
- Ambient Temperature: $20 \pm 15^\circ\text{C}$
 - Relative Humidity: $65\% \pm 20\%$
 - Air Pressure: 86KPa to 106KPa
- 5.1.2 If any doubt on the results, measurements/tests should be made within the following limits:
- Ambient Temperature: $20 \pm 2^\circ\text{C}$
 - Relative Humidity: $65\% \pm 5\%$
 - Air Pressure: 86KPa to 106Kpa

5.2 Visual Examination

- Inspection Equipment: 10X magnifier

5.3 Electrical Test

- 5.3.1 Inductance (L)
- Refer to the third item.
 - Test equipment: IM3536 LCR meter or equivalent.
 - Test Frequency and Voltage: Refer to the third item.
- 5.3.2 Direct Current Resistance (DCR)
- Refer to the third item.
 - Test equipment: VR126 or equivalent.
- 5.3.3 Saturation Current (I_{sat})
- Refer to the third item.
 - Test equipment: Saturation current meter
 - Definition of saturation current (I_{sat}): DC current at which the inductance drops approximate 40% from its value without current.
- 5.3.4 Temperature rise current (I_{rms})
- Refer to the third item.
 - Test equipment (see Fig.5.3.4-1): Electric Power, Electric current meter, Thermometer.
 - Measurement method (see Fig. 5.3.4-1):
 - Set test current to be 0mA.
 - Measure initial temperature of choke surface.
 - Gradually increase current and measure choke temperature for corresponding current.
 - Definition of Temperature rise current: DC current that causes the temperature rise ($\Delta T = 40^\circ\text{C}$) from 20°C ambient (see Fig. 5.3.4-2).

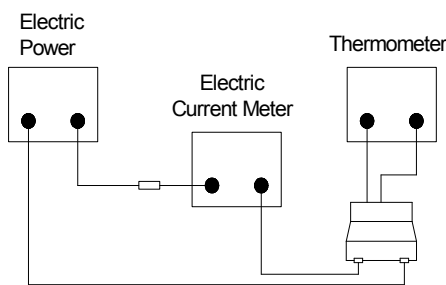

Fig.5.3.4-1

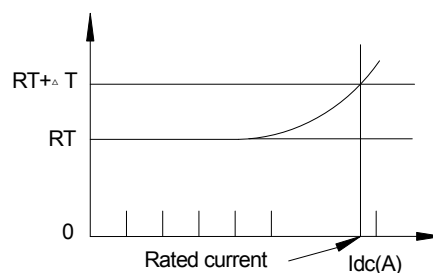
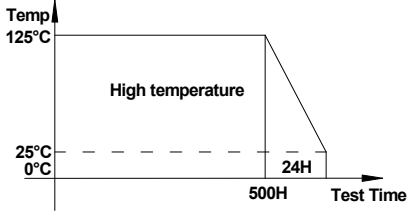
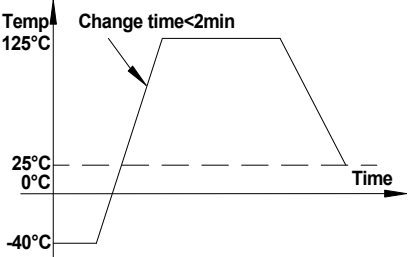
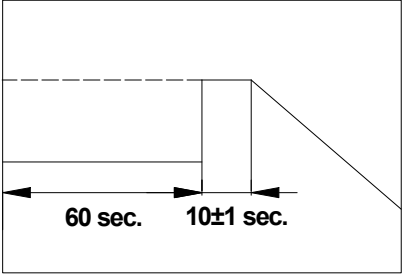
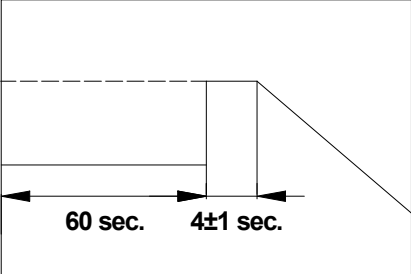

Fig.5.3.4-2

5.4 Reliability Test

Item	Specifications	Test conditions
<p>5.4.1 High temperature storage test</p>	<p>No visible mechanical damage. Inductance change: Within $\pm 10\%$.</p>	<p>Temperature: $125 \pm 2^\circ\text{C}$. Duration: 500hrs. Measured at room temperature after placing for 24 ± 4 hrs.</p> 
<p>5.4.2 Temperature cycling test</p>	<p>No visible mechanical damage. Inductance change: Within $\pm 10\%$.</p>	<p>Condition for 1 cycle. Step1: $-40 \pm 2^\circ\text{C}$ 30min Min. Step2: $125 \pm 2^\circ\text{C}$, transition time 2min Max. Step3: $125 \pm 2^\circ\text{C}$ 30min Min. Step4: Low temp, transition time 2min Max. Number of cycles: 100. Measured at room temperature after placing for 24 ± 4 hrs.</p> 
<p>5.4.3 Biased humidity test</p>	<p>No visible mechanical damage. Inductance change: Within $\pm 10\%$.</p>	<p>Humidity : $85\% \pm 3$ RH. Temperature: $60^\circ\text{C} \pm 2^\circ\text{C}$. Duration : 500hrs. Measured at room temperature after placing for 24 ± 4 hrs.</p>
<p>5.4.4 Operational life test</p>	<p>No visible mechanical damage. Inductance change: Within $\pm 10\%$.</p>	<p>Temperature: $85 \pm 2^\circ\text{C}$. Duration : 500hrs. Measured at room temperature after placing for 24 ± 4 hrs.</p>
<p>5.4.5 Resistance to solvent test</p>	<p>No visible mechanical damage. Inductance change: Within $\pm 10\%$.</p>	<p>Add aqueous wash chemical - OKEM clean or equivalent.</p>
<p>5.4.6 Vibration test</p>	<p>No visible mechanical damage. Inductance change: Within $\pm 10\%$.</p>	<p>The sample shall be soldered onto the printed circuit board and when a vibration having an amplitude of 1.52mm and a frequency of from 10 to 55Hz/1 minute repeated should be applied to the 3 directions (X,Y,Z) for 2 hours each.(A total of 6 hours)</p>

Item	Specifications	Test conditions
<p>5.4.7 Resistance to soldering heat test</p>	<p>No visible mechanical damage. Inductance change: Within $\pm 10\%$.</p>	<p>Temperature ($^{\circ}\text{C}$): 260 ± 5 (solder temp). Time (s): 10 ± 1. ramp/immersion and emersion rate: $25\text{mm/s} \pm 6 \text{ mm/s}$. Number of heat cycles:1.</p> 
<p>5.4.8 Solderability test</p>	<p>More than 95% of the terminal electrode should be covered with solder.</p>	<p>Steam Aging: 8 hours \pm 15 min. Preheat: 150°C, 60sec. Solder: Sn99.5%-Cu0. 5%. Temperature: $245 \pm 5^{\circ}\text{C}$. Flux for lead free: Rosin. 9.5%. Dip time: 4 ± 1sec. Depth: completely cover the termination.</p> 
<p>5.4.9 Terminal strength (SMD) test</p>	<p>No visible mechanical damage.</p>	<p>With the component mounted on a PCB with the device to be tested, apply a 10 N force to the side of a device being tested. This force shall be applied for 10 ± 1 seconds. Also the force shall be applied radually as not to apply a shock to the component being tested.</p>

6. Packaging, Storage

6.1 Tape and Reel Packaging Dimensions

6.1.1 Taping Dimensions (Unit: mm)

Please refer to Fig. 6.1.1-1

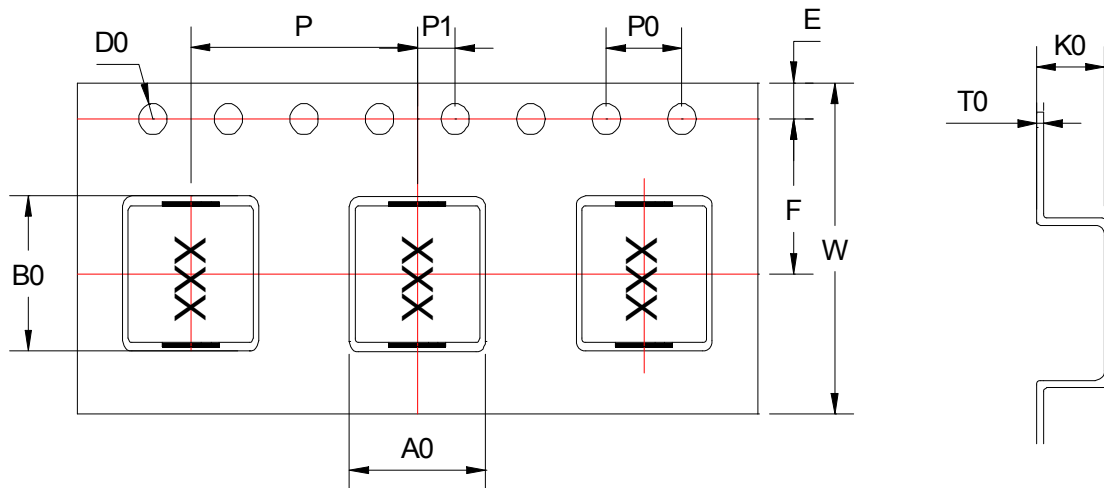

Fig.6.1.1-1

TYPE	A0	B0	W	E	F	P0	P	P1	D0	T0	K0
APS07A50	7.2±0.1	7.5±0.1	16.0±0.3	1.75±0.1	7.5±0.1	4.0±0.1	12.0±0.1	2.0±0.1	1.5±0.1	0.4±0.1	5.6±0.1

6.1.2 Reel Dimensions (Unit: mm)

Please refer to Fig. 6.1.2-1.

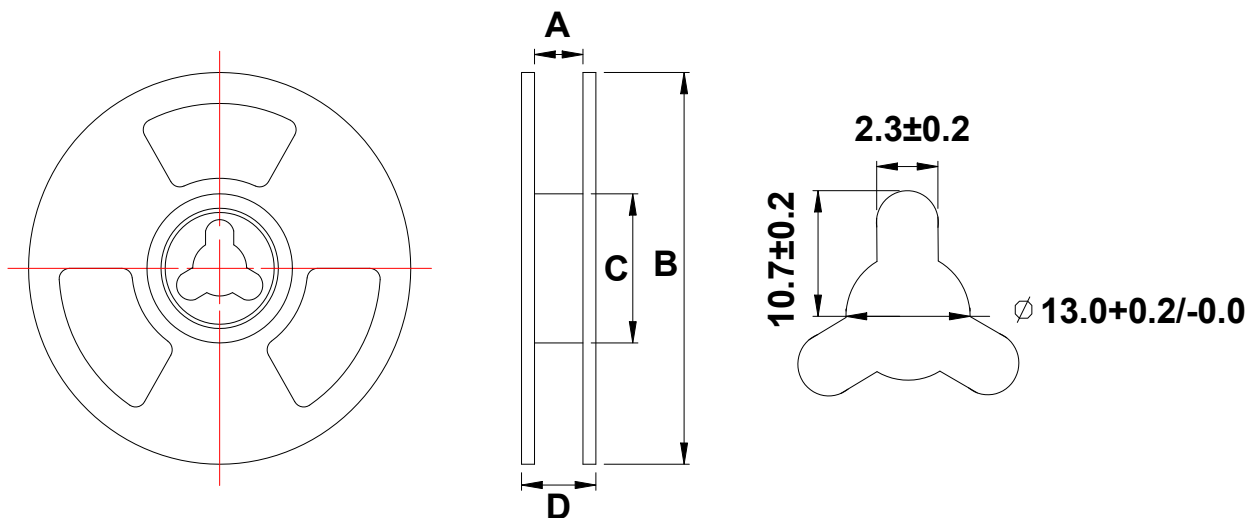

Fig. 6.1.2-1.

TYPE	A	B	C	D
APS07A50	16.5±2.0	330.0±2.0	100.0±2.0	20.5±2.0

6.2 Packaging

6.2.1 The inner box specification: 350*340*40MM

Packing quantity: 2000 PCS/ box

Bubble bag: 37*45CM

Job description: putting the air bubble bag products placed inside the box, sealed with scotch tape.

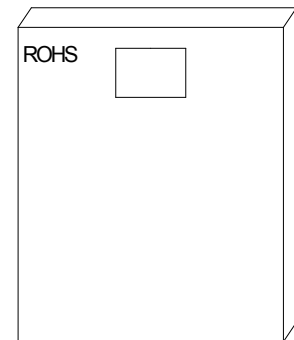

6.2.2 The outside box specification: 370*360*255MM

Packing quantity: 10000 PCS/ box

Job description: will be outside the box bottom sealed, inner box into the box.

- a. With transparent tape sealed box at the top.
- b. The specified location with a box labels in the outer box.
- c. If the mantissa box under a FCL with inner box for filling full.

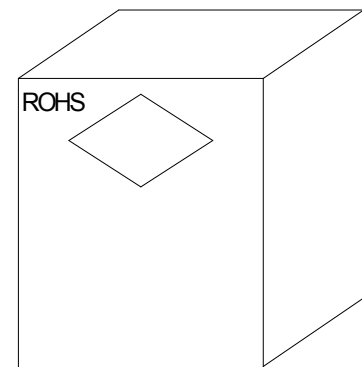

6.3 Storage

- a. To maintain the solderability of terminal electrodes and to keep the packing material in good condition, temperature and humidity in the storage area should be controlled.
- b. Recommended conditions: -10°C~40°C, 70%RH (Max).
- c. Even under ideal storage conditions, solderability of products electrodes may decrease as time passes.
For this reason, product should be used with one year from the time of delivery.
- d. In case of storage over one year, solderability shall be checked before actual usage.

7. Recommended Soldering Technologies

7.1 Re-flowing Profile:

- △ Preheat condition: 150~200°C/60~120sec.
- △ Allowed time above 217°C: 60~90sec.
- △ Max temp: 260°C
- △ Max time at max temp: 5sec.
- △ Solder paste: Sn/3.0Ag/0.5Cu
- △ Allowed Reflow time: 2x max

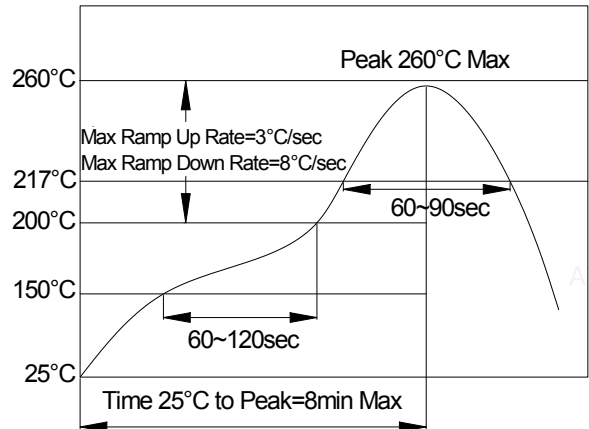

7.2 Iron Soldering Profile:

- △ Iron soldering power: Max.30W
- △ Pre-heating: 150°C/60sec.
- △ Soldering Tip temperature: 350°C Max.
- △ Soldering time: 3sec Max.
- △ Solder paste: Sn/3.0Ag/0.5Cu
- △ Max.1 times for iron soldering

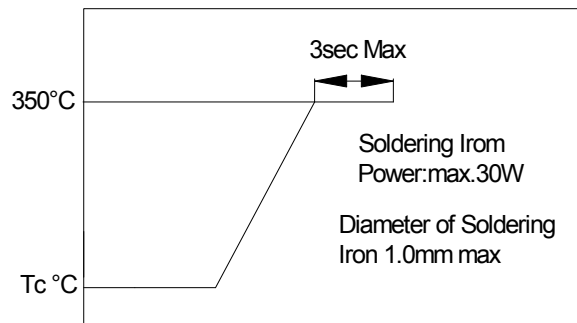

[Note: Take care not to apply the tip of the soldering iron to the terminal electrodes.]